









## EWV0910ZZ

May 2010 – Rev 2

*Production*

### Features

-  Dual Output Frequencies
-  Push-push Architecture
-  Phase Noise : -111 dBc/Hz @ 100 kHz
-  Output Power at  $f_{out}$ : +18 dBm, typical
-  Output Power at  $f_{out/2}$ : 0 dBm, typical
-  Die Size: 2.0 x 3.2 x 1mm
-  100% RF and DC Tested
-  RoHS Compliant

### Device Photo

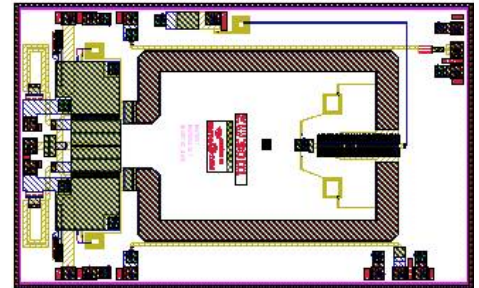

### Description

The Endwave EWV0910ZZ is a high performance InGaP/GaAs HBT MMIC voltage controlled oscillator which provides a set of dual outputs ideal for applications which require 8.68 to 8.98 or 4.34 to 4.49 GHz outputs. The device boasts state of the art phase noise at better than - 111 dBc/Hz at a 100 kHz offset . This device can be used in a wide range of applications from defense electronics to commercial communication systems. All die are 100% DC and RF tested and visually inspected to Mil-Std-883 Method 2010.

### Block Diagram

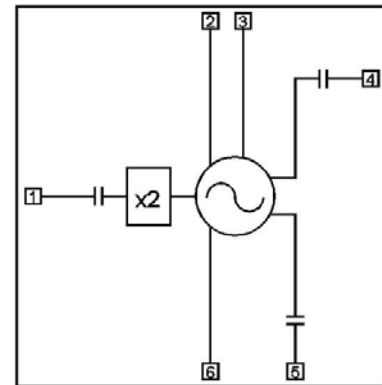

### Electrical Characteristics (Temperature = +25 °C, $V_{cc} = 4.20V$ )

Parameter	Min.	Typ.	Max.	Units
Frequency Range ( $f_{out}$ )	8.68		8.98	GHz
Frequency Range ( $f_{out/2}$ )	4.34		4.49	GHz
Output Power ( $f_{out}$ )	+14	+18	+21	dBm
Output Power ( $f_{out/2}$ )	-4	0	+4	dBm
Phase Noise @ $f_{out}$ 100 kHz Offset, $V_{tune} = +5V$		-111		dBc/Hz
Tune Voltage	2		13	V
Supply Current	140	180	210	mA
Tune Port Leakage Current, $V_{tune} = 13V$			25	uA
Output Return Loss		5		dB
Harmonic / Sub-harmonics				
$\frac{1}{2}$	35	46		dBc
$2^{nd}$	15	22		dBc
Pulling (into a 2:1 VSWR)		5		MHz pp
Pushing @ $V_{tune} = 5V$		6		MHz/V
Frequency Drift Rate			-1.0	MHz/ C

RF Frequency vs. Tuning Voltage,  $V_{CC} = 4.2V$

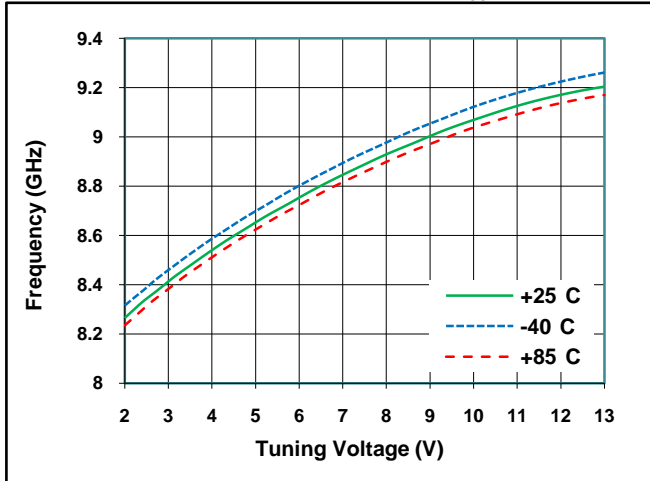

RF Sensitivity vs. Tuning Voltage,  $V_{CC} = 4.2V$

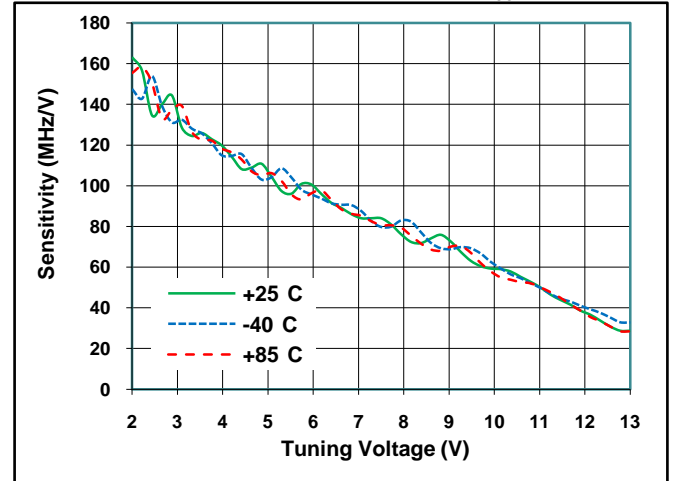

RF Output Power vs. Tune Voltage,  $V_{CC} = 4.2V$

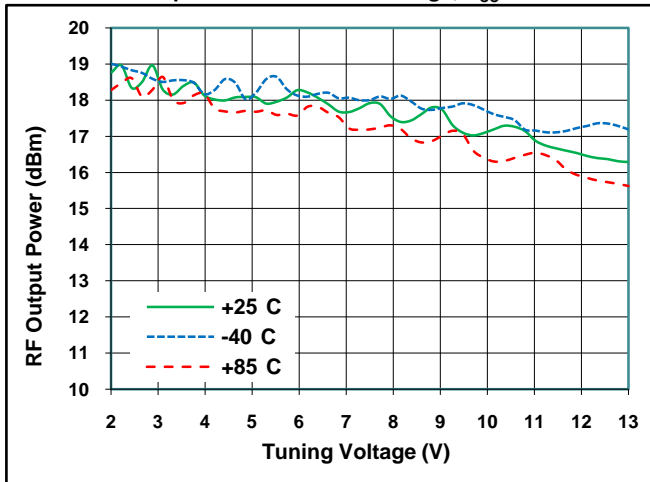

RF/2 Output Power vs. Tune Voltage,  $V_{CC} = 4.2V$

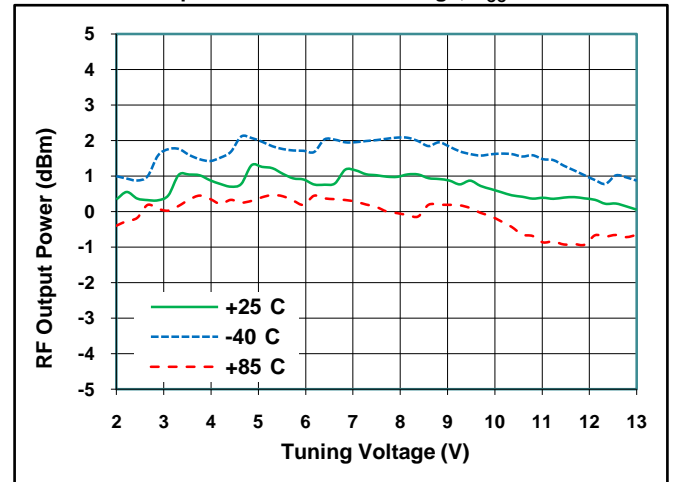

SSB Phase Noise @ RF Output vs. Tuning Voltage

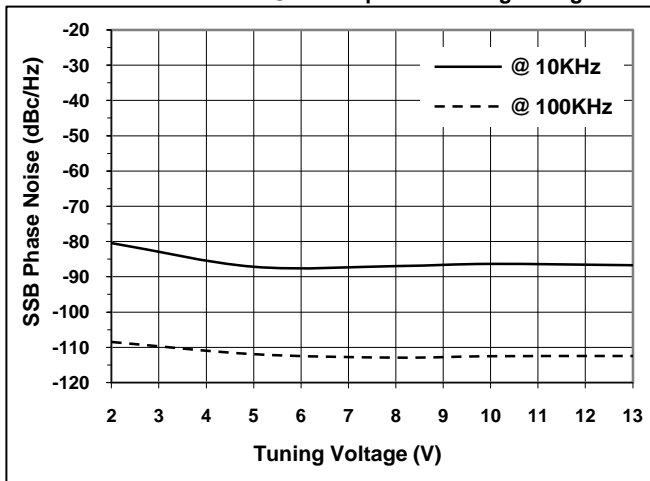

SSB Phase Noise @ RF Output vs.  $V_{tune} = 8V$

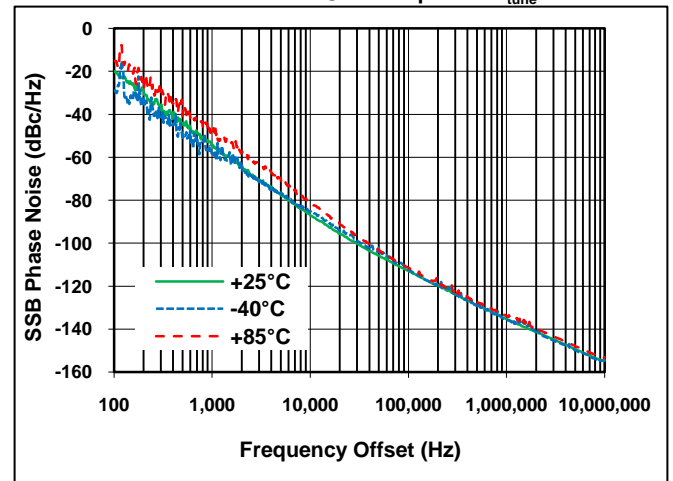

Voltage Controlled Oscillators – Bare Die

## EWV0910ZZ

May 2010 – Rev 2

*Production*

### Assembly Drawing

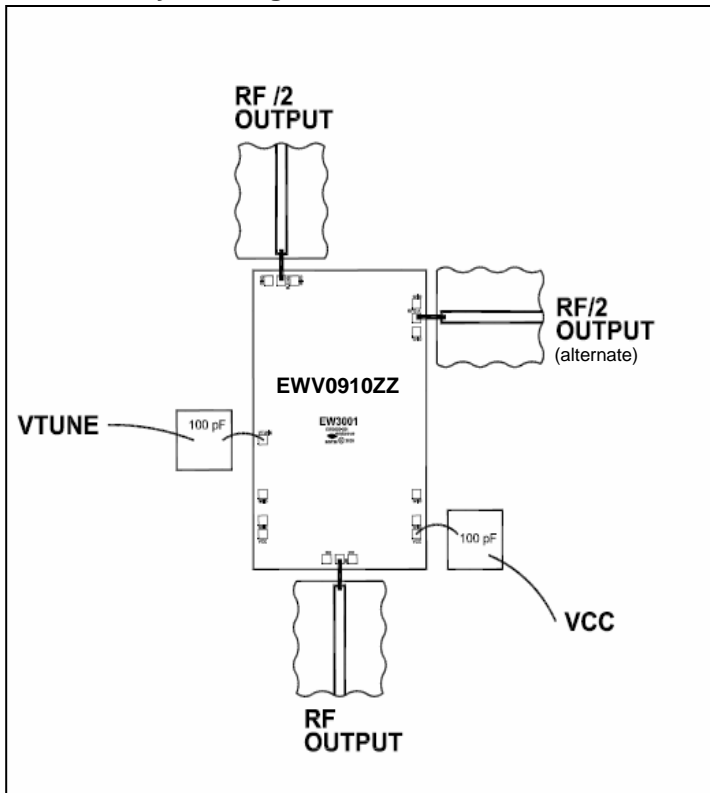

NOTE: Large-value 10 nF capacitors need to be added to the  $V_{CC}$  bias line for best phase noise performance.

### Outline Drawing

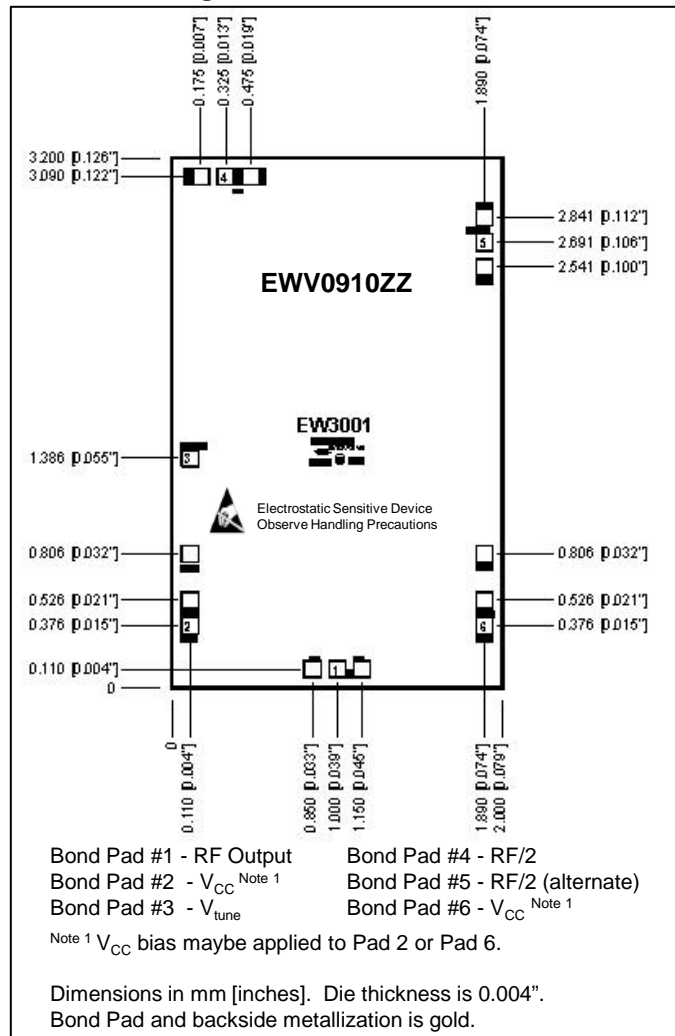

### Absolute Maximum Ratings

Supply Voltage, $V_{cc}$	+4.5V
Tune Voltage, $V_{tune}$	+0 to +15 V
Channel Temperature	135°C
Continuous Power Dissipation at 25°C	1.32W
Supply Current, $I_{cc}$	330mA
Storage Temperature	-65° to +150°C
Operating Temperature	-40° to +85°C

### Typical Supply Current

$V_{cc}$	$I_{cc}$
4.0 V	160mA
4.2 V	180 mA
4.4 V	200 mA

### Typical Application

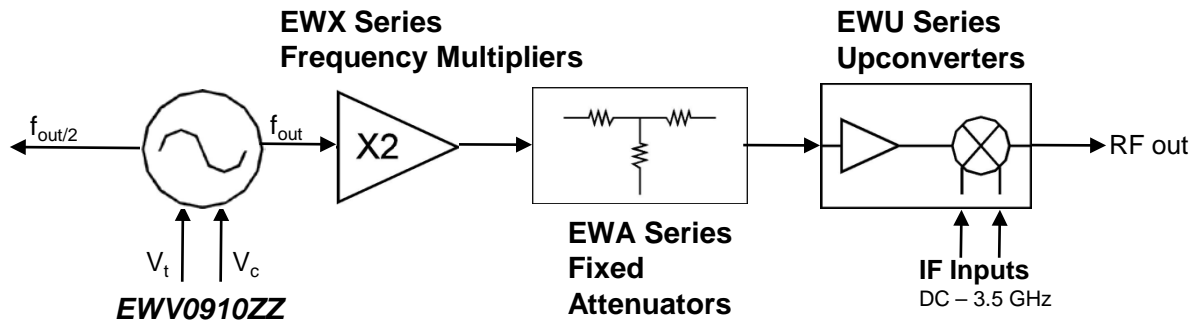

### Support Documentation

Support documentation including Assembly Notes, Application Notes and Qualification Procedures can be found on our website at [www.endwave.com](http://www.endwave.com).

### Ordering Information

Part Number	Description
EWV0910ZZ	RoHS compliant bare die in waffle or gel packs
EWV0910ZZ-EV	EWV0910ZZ in a Connectorized Test Fixture