











EWD1509YF

Features

-  Extremely high integration
-  Includes converter, LO amplifier, RF VGA
-  Noise figure: 2.5 dB, typical at max gain
-  Conversion gain: +15 dB, typical
-  Input IP3: +4 dBm, typical
-  Image rejection: 15 dB, typical
-  Low power consumption : +4.5V @ 220 mA
-  HBM Class 1A - ESD Protection Bias Circuitry
-  Package: 5 x 5 mm, 32 lead, plastic overmold QFN
-  RoHS compliant
-  100% DC and RF tested

Device Photo



Description

The Endwave *EWD1509YF* is a highly integrated GaAs PHEMT MMIC down-converter that includes LO amplification, along with RF gain adjustability via a unique voltage variable attenuator. The device provides 15 dB of conversion gain with 15 dB of RF gain adjustability, while maintaining +4 dBm input third order intercept over all conditions with 0 dBm of LO input power. This device has integrated ESD protection bias circuitry and can be used for a wide range of applications from defense electronics to commercial communication systems. All parts are 100% DC and RF tested and visually inspected to IPC-A-610.

Block Diagram

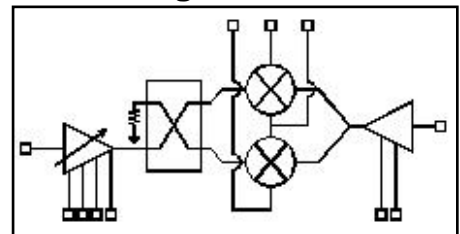

Electrical Characteristics (Temperature = +25°C)

Parameter	Min.	Typ.	Max.	Units
Frequency Range, IF	DC		4	GHz
Frequency Range, RF	10		15.4	GHz
Frequency Range, LO	6		19.4	GHz
Conversion Gain (at max gain)	10	15		dB
Dynamic Range (Vgc1,2 + 0 vs. -1.5V)		15		dB
Image Rejection		15		dBc
LO Drive Power		0		dBc
Input 3 rd -Order Intercept (all gain settings)	+2	+4		dBm
Noise Figure (at maximum gain)		2.5	3	dB
Noise Figure (at minimum gain)			15	dB
IF Return Loss		10		dB
LO Return Loss		10		dB
RF Return Loss		10		dB
Drain Bias Voltages (Vd1, Vd2, Vd3)		+4.5		V
Drain Bias Currents (Id1+Id2+Id3)		220		mA
Gate Bias Voltage (Vg3)		-1.1		V
Gate Bias Voltage (Vg4)		-0.6		V
Gate Control Voltage (Vgc1,2)	-1.5		0	V

EWD1509YF

Preliminary

Downconverters - Packaged

Conversion Gain

VG3=-1.2V, IF=2 GHz from external 90-degree hybrid,
 $P_{LO}=0$ dBm at $F_{LO} = F_{RF} - F_{IF}$

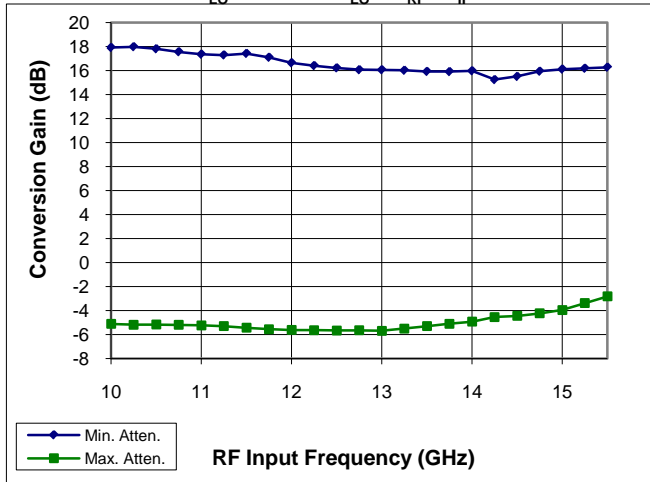

LO-to-IF Isolation

VG3=-1.2V, IF=2GHz from external 90-degree hybrid,
 $P_{LO}=0$ dBm at $F_{LO} = F_{RF} - F_{IF}$

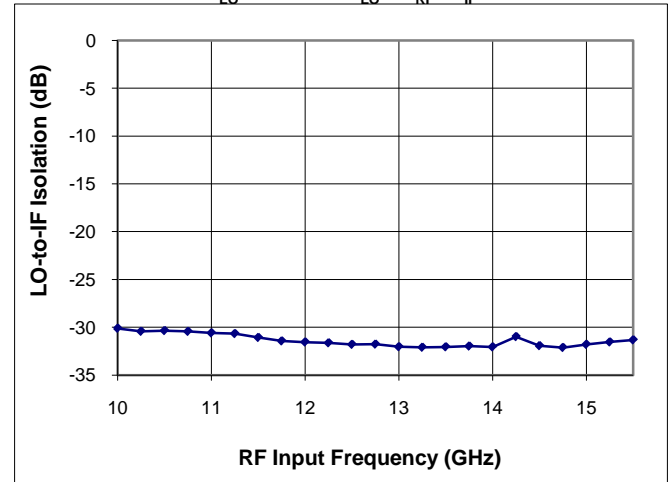

Return Loss

VG3=-1.2V, IF connected to external 90-degree hybrid,
 $P_{LO}=0$ dBm at $F_{LO} = F_{RF} - F_{IF}$

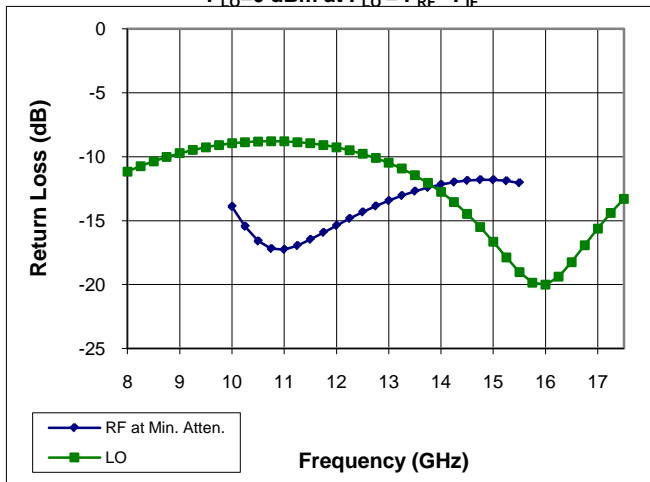

Dynamic Range

VG3=-1.2V, IF=2GHz from external 90-degree hybrid,
 $P_{LO}=0$ dBm at $F_{LO} = F_{RF} - F_{IF}$

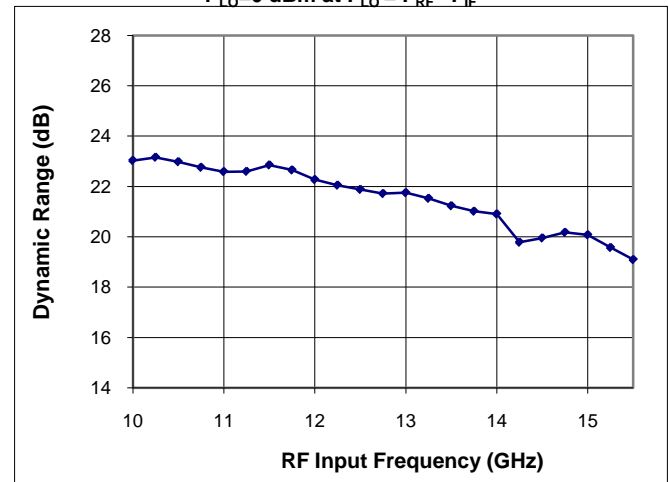
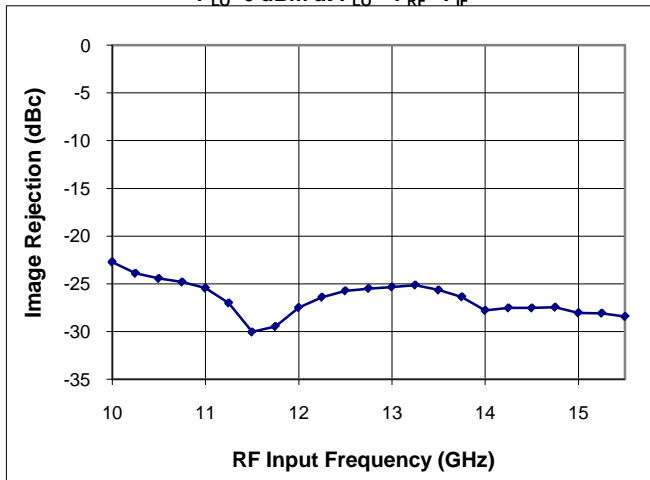

Image Rejection

VG3=-1.2V, IF=2GHz from external 90-degree hybrid,
 $P_{LO}=0$ dBm at $F_{LO} = F_{RF} - F_{IF}$



Noise Figure

VG3=-1.2V, IF=2GHz from external 90-degree hybrid,
 $P_{LO}=0$ dBm at $F_{LO} = F_{RF} - F_{IF}$

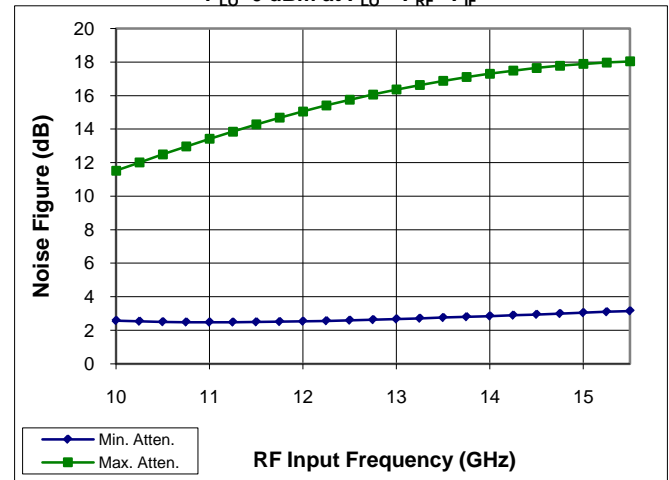

DC & RF Pinout

Pin Number	Function
1-5, 15, 16, 20, 21, 23, 24, 30, 31, 32	No Connection
6, 8, 17, 19, 25, 27, 29	Ground
7	RF Input
9	V_{GC1}
10	V_{GC2}
11	V_{G4} (Note 2)
12	V_{D3} (Note 2)
13	V_{D2} (Note 2)
14	V_{D1} (Note 2)
18	LO Input
22	V_{G3} (mixer bias)
26	IF Output2 (Note 1)
28	IF Output1 (Note 1)

Note 1: Combine IF outputs via external 90-degree hybrid to create image rejection.

Note 2: Place 100pF bypass chip capacitor as close as possible to the pin.

Outline Drawings

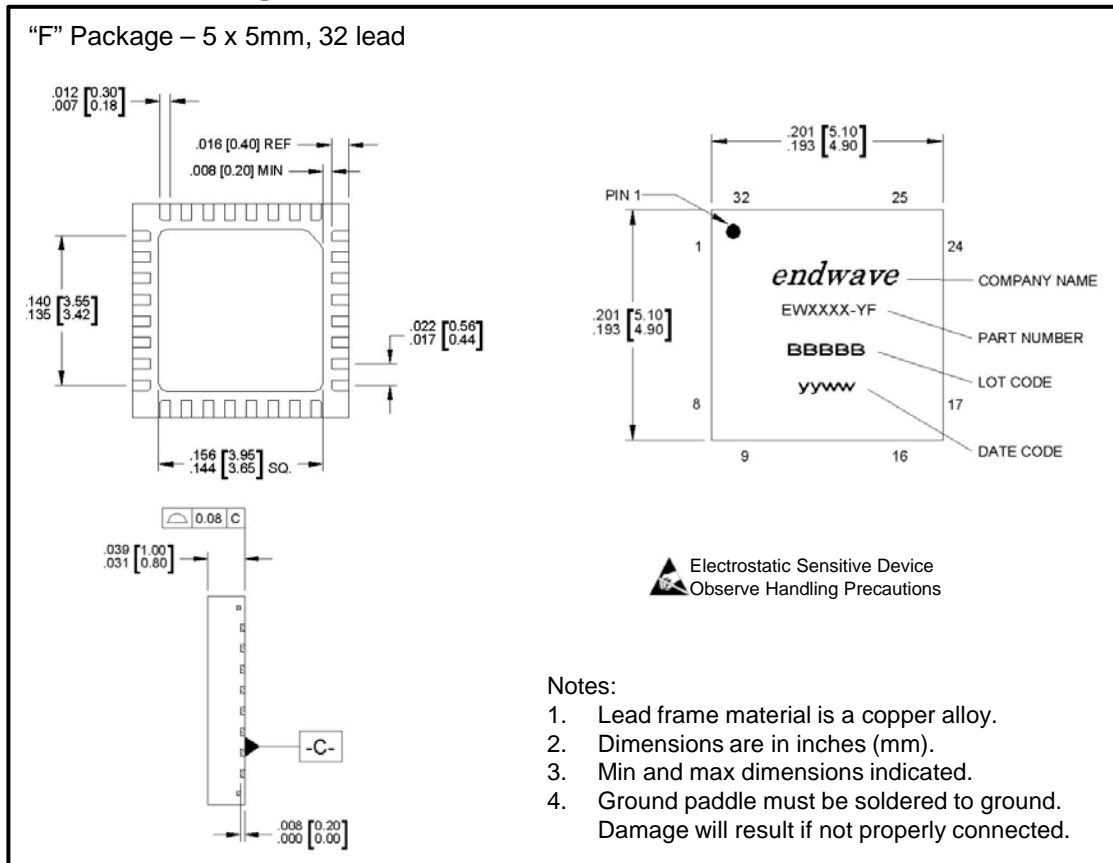

Absolute Maximum Ratings

RF Input Power	+10 dBm
LO Input Power	+15 dBm
Supply Voltage (V_{dtotal})	+5.5 V
Supply Current (I_{dtotal})	700 mA
Storage Temperature	-65 to +150 °C
Operating Temperature	-40 to +85 °C
Channel Temperature	175 °C

Typical Application

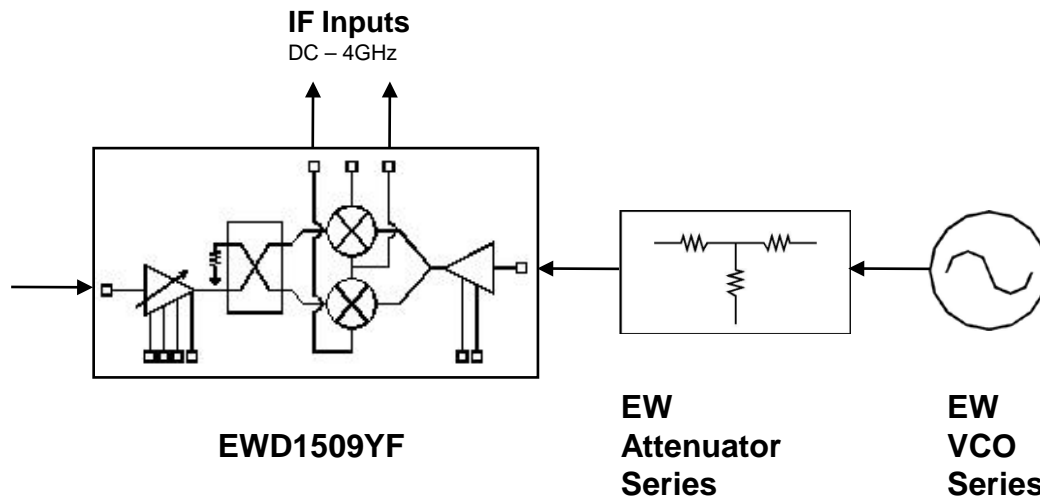

Support Documentation

Support documentation including Assembly Notes, Application Notes and Qualification Procedures can be found on our website at www.endwave.com.

Ordering Information

Part Number	Description
<i>EWD1509YF</i>	RoHS compliant, 5 x 5mm, 32 lead, QFN "F" package
<i>EWD1509YF-EV</i>	<i>EWD1509YF</i> on an Evaluation Board